



Assembly Precautions for the Nichia 146 Series LEDs

Table of contents

1.	<u>LED Outline Dimensions/Tape and Reel Dimensions</u>	2
2.	<u>Handling Precautions</u>	3
3.	<u>Design Recommendations for Optimal Amount of Solder</u>	4
4.	<u>Precautions for Setting Up a Pick-and-Place Machine/Nozzle</u>	5-9
5.	<u>Precautions When Reflow Soldering</u>	9
6.	<u>Evaluation of the Effect of Solder Volume</u>	10-12

NSSW146A and NxSx146x refer to Nichia part numbers. These Nichia part numbers within this document are merely Nichia's part numbers for those Nichia products and are not related nor bear resemblance to any other company's product that might bear a trademark.

This document contains tentative information, Nichia may change the contents without notice.

1. LED Outline Dimensions/Tape and Reel Dimensions

Table 1. NxSx146x Product Specifications

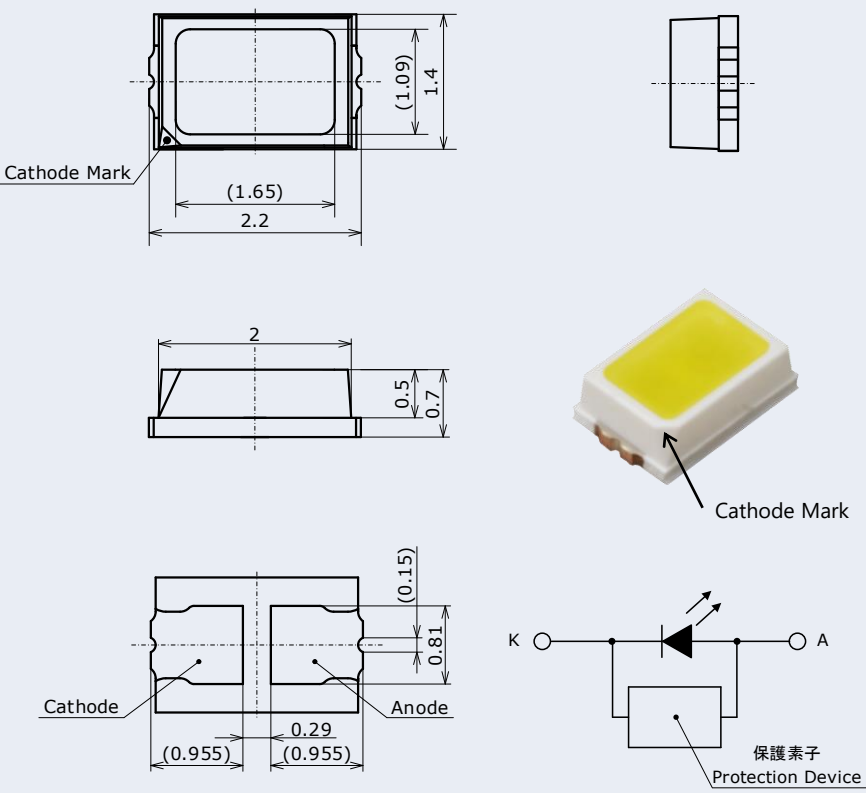
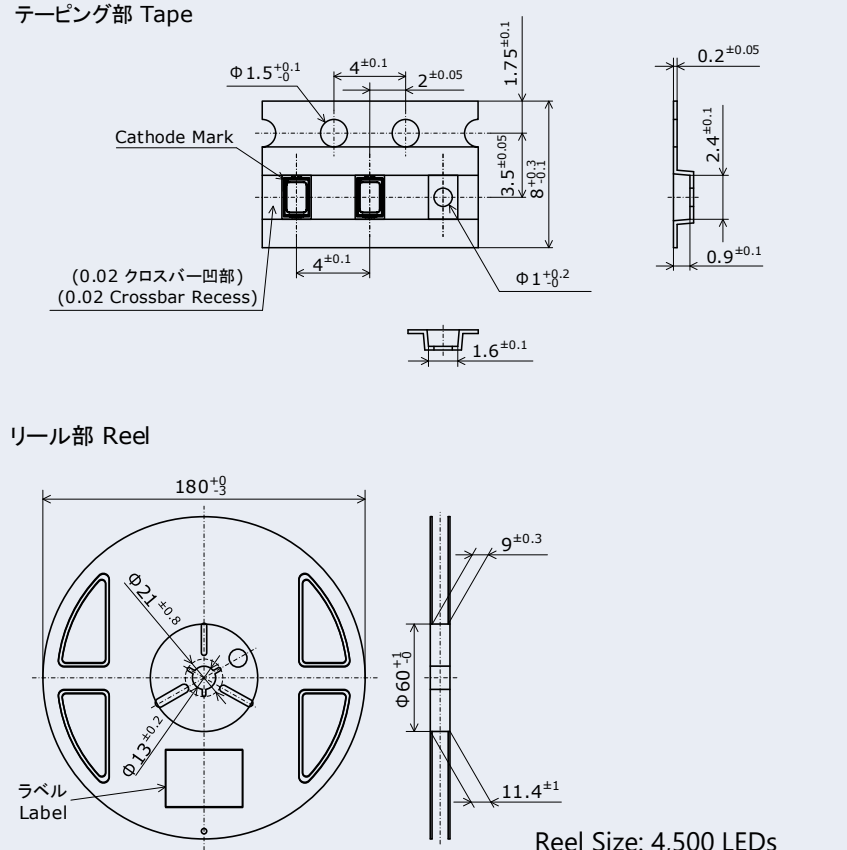
LED	Embossed Carrier Tape
 <p> Cathode Mark (1.65) 2.2 (1.09) 1.4 2 0.5 0.7 Cathode Mark Cathode Anode 0.29 (0.955) (0.955) (0.15) 0.81 K A 保護素子 Protection Device Weight: typ. 0.0050g (Unit: mm, Tolerance: ±0.1mm) </p>	 <p> テーピング部 Tape Cathode Mark (0.02 クロスバー凹部) (0.02 Crossbar Recess) $\Phi 1.5^{+0.1}_{-0.1}$ $4^{\pm 0.1}$ $2^{\pm 0.05}$ $1.75^{\pm 0.1}$ $3.5^{\pm 0.05}$ $8^{\pm 0.1}$ $\Phi 1^{\pm 0.2}$ $0.2^{\pm 0.05}$ $2.4^{\pm 0.1}$ $0.9^{\pm 0.1}$ $1.6^{\pm 0.1}$ リール部 Reel 180^{+0}_{-3} $\Phi 27^{\pm 0.8}$ $\Phi 13^{\pm 0.2}$ ラベル Label $9^{\pm 0.3}$ $\Phi 60^{+1}$ $11.4^{\pm 1}$ Reel Size: 4,500 LEDs (Unit: mm) </p>

The weight value provided in Table 1 is the weight for the NSSW146A LED.

This document contains tentative information, Nichia may change the contents without notice.

2. Handling Precautions

2-1. Handling with Bare Hands

Do not handle the LEDs with bare hands:

- this may contaminate the LED surface and have an effect on the optical characteristics,
- this may cause the LED to deform and/or the wire to break causing a catastrophic failure (i.e. the LED not to illuminate),

2-2. Handling with Tweezers

Ensure that when handling the LEDs with tweezers, excessive force is not applied to the LED. Otherwise, it may cause damage to the resin (e.g. cut, scratch, chip, crack, delamination and deformation) and/or the wire to break causing a catastrophic failure.

2-3. ESD Precautions

The LEDs are sensitive to transient excessive voltages (e.g. ESD, lightning surge). If this excessive voltage occurs in the circuit, it may cause the LED to be damaged causing issues (e.g. the LED to become dimmer or not to illuminate [i.e. catastrophic failure]). When handling the LEDs, ensure that necessary measures have been taken to protect them from transient excess voltages. Refer to the applicable specification for more details.

2-4. Stacking Assembled PCBs Together

Do not stack assembled PCBs together. Otherwise, it may cause damage to the resin (e.g. cut, scratch, chip, crack, delamination and deformation) and the wire to break causing a catastrophic failure.

2-5. Baking

The NxSx146x LEDs are comparable to JEDEC Moisture Sensitivity Level (MSL) 2a or equivalent. Refer to IPC/JEDEC STD-020 for detailed information regarding the MSL. If the "after opening" storage time is exceeded, or if pink silica gel beads are found, make sure the LEDs are baked before use. Baking should be done only once. When baking the LEDs, remove the reel of the LEDs from the moisture-proof aluminum bag.

Table 2. Storage/Baking Conditions

Conditions		Temperature	Humidity	Time
Storage	Before Opening the Moisture-proof Aluminum Bag	≤30°C	≤90%RH	Within 1 Year from Delivery Date
	After Opening the Moisture-proof Aluminum Bag	≤30°C	≤70%RH	Within 4 Weeks
Baking		65±5°C	-	≥24 Hours

✓ Correct

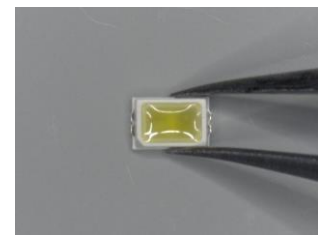

⊘ Incorrect

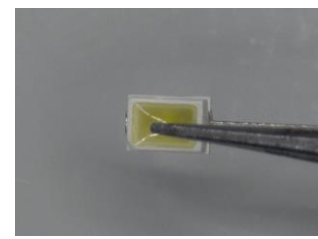

⊘ Incorrect

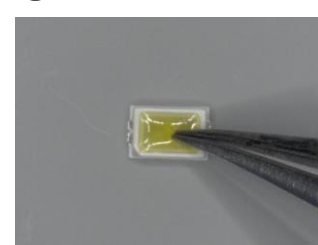

Figure 1. Correct/Incorrect Examples of Handling with Tweezers

This document contains tentative information, Nichia may change the contents without notice.

3. Design Recommendations for Optimal Amount of Solder

Soldering Pad Pattern/Metal Solder Stencil Aperture

Table 3. Recommended Soldering Pad Pattern/Metal Solder Stencil Aperture

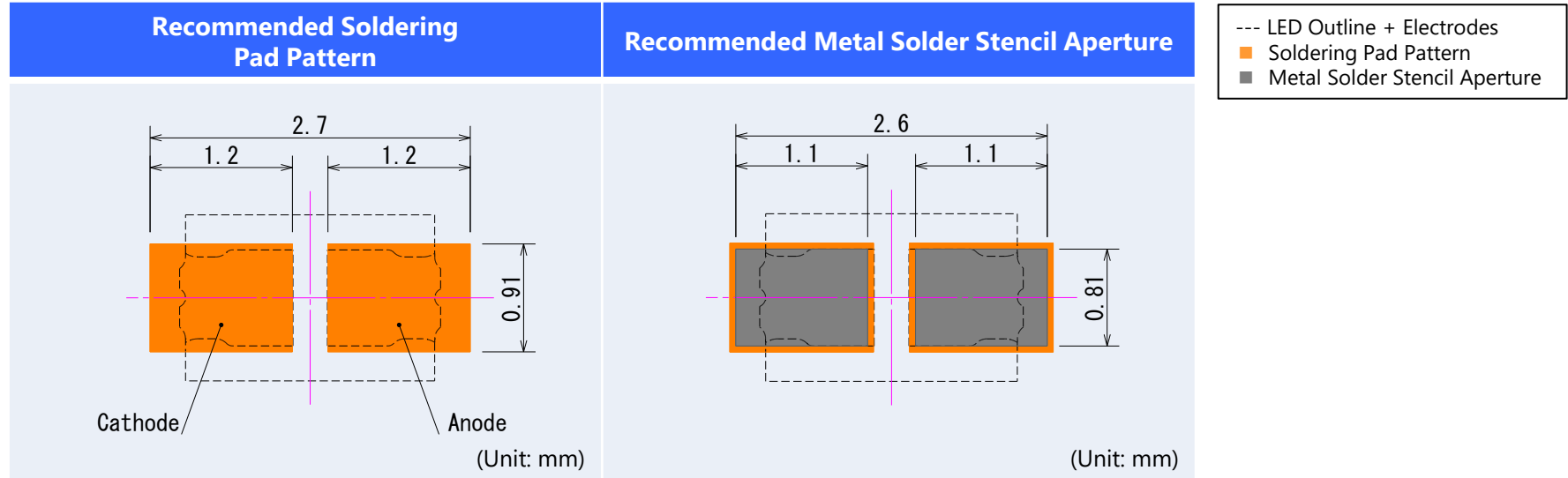

Table 4. Recommended Solder/Metal Solder Stencil Conditions

Item	Recommended Conditions
Metal Solder Stencil (Thickness)	100µm
Solder Paste (Composition)	Sn-3.0Ag-0.5Cu

The recommended soldering pad pattern, metal solder stencil aperture, and thickness of the metal solder stencil provided in Tables 3 and 4 have been determined under Nichia’s conditions: ensure that there are no issues with the chosen assembly conditions prior to use.

This document contains tentative information, Nichia may change the contents without notice.

4. Precautions for Setting Up a Pick-and-Place Machine/Nozzle

Table 5. Cautions/Suggestions for Setting Up Equipment

Item	Recommended Conditions/Specifications	Cautions/Suggestions
Pick-and-Place Machine	Modular mounter	The recommended conditions/specifications herein have been determined using YS100 High-Speed General-Purpose Modular (manufactured by Yamaha Motor Co., Ltd.).
Pick-and-Place Nozzle	Use a nozzle that is appropriate for the dimensions of the LED.	See "4-1. Pick-and-Place Nozzle" on Page 6 for details.
Tape-and-Reel Feeder	Electrical (motorized) feeder Tape width: 8mm Feeder pitch: 4mm	See "4-2. Tape-and-Reel Feeder" on Page 7 for details.
Top Cover Tape Removal Position	Sufficiently far away from the LED pick-up position.	See "4-2. Tape-and-Reel Feeder" on Page 7 for details.
Nozzle Height for Pick-up Operations	The contact surface of the nozzle head for pick operations should be adjusted to 0.2mm below the edge of the embossed carrier tape pocket.	See "4-3. Recommended Nozzle Height for Pick-up Operations" on Page 8 for details.
Nozzle Height for Placement Operations (i.e. Placement Depth)	0.2mm for placement depth	See "4-4. Recommended Nozzle Height for Placement Operations (Placement Depth)" on Page 8 for details.
Imaging-based Automatic Inspection	Using the electrode as a reference is recommended to locate the center of the LED.	See "4-5. Imaging-based Automatic Inspection" on Page 9 for details.

This document contains tentative information, Nichia may change the contents without notice.

4-1. Pick-and-Place Nozzle

1. Figure 2 shows a recommended nozzle tip.

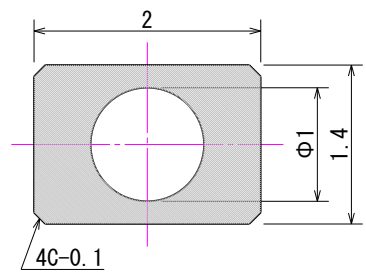

(Unit: mm)

Figure 2. Recommended Nozzle Tip

2. Use a nozzle that is appropriate for the LED (i.e. the nozzle dimensions are appropriate for the dimensions of the recommended pick-up position for the LED).

Do not use a nozzle that is smaller than the emitting area of the LED (i.e. 1.65mm x 1.09mm); otherwise, it may damage the emitting surface causing the LED not to illuminate.

Figure 4 shows correct/incorrect examples for shapes of the nozzle and LED pick-up positions for reference purposes.

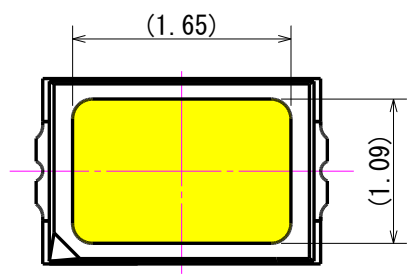

(Unit: mm)

Figure 3. Emitting Area of the LED

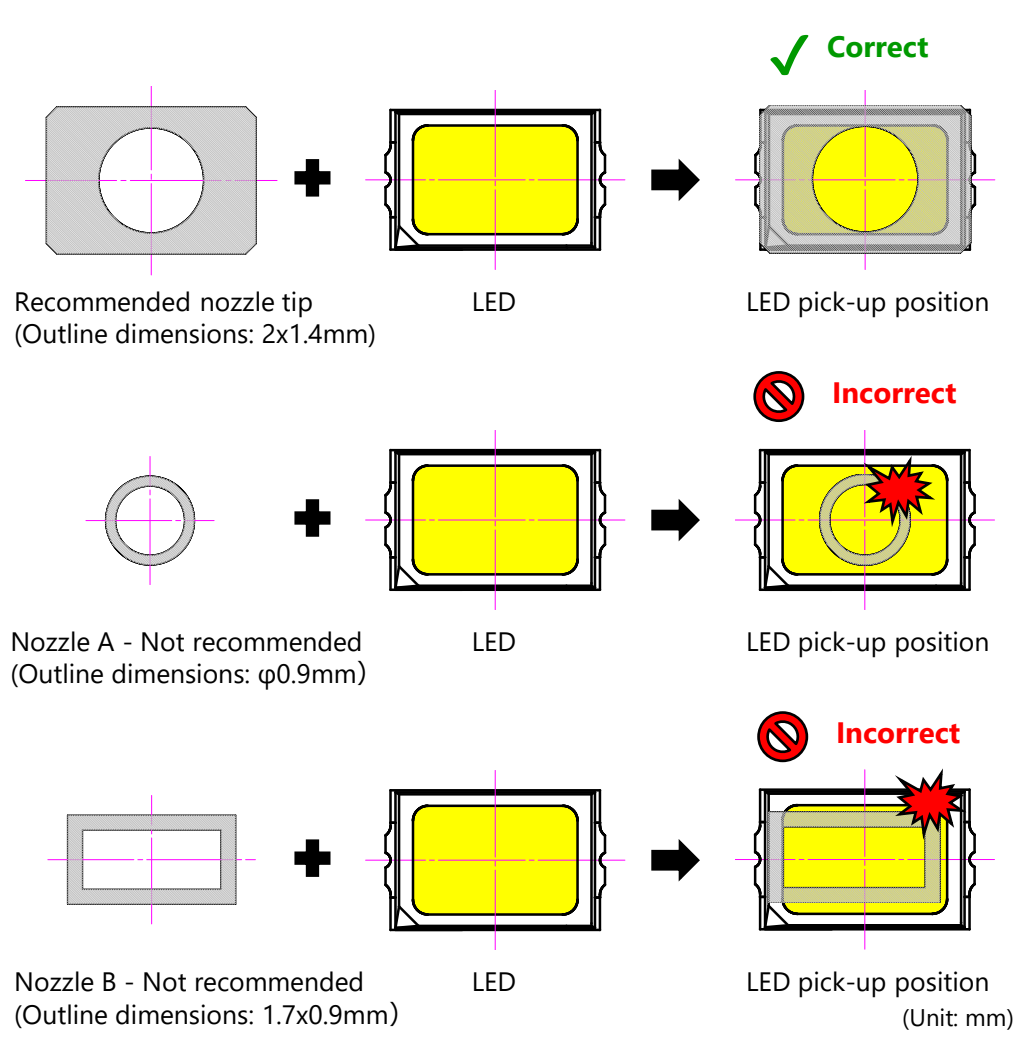
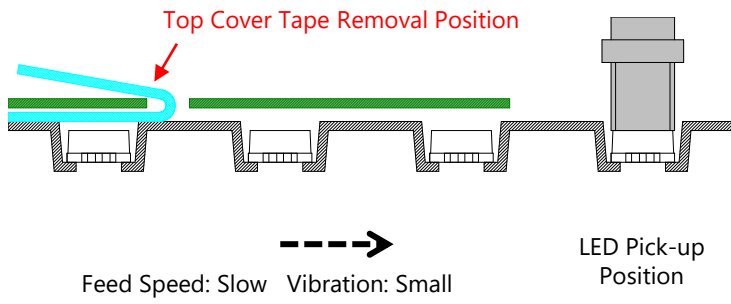

Figure 4. Correct/Incorrect Examples for Shapes of the Nozzle and LED Pick-up Positions

This document contains tentative information, Nichia may change the contents without notice.

4-2. Tape-and-Reel Feeder

• It is **recommended** to remove the top cover tape at a point sufficiently far away from the LED pick-up position.



• It is **not recommended** to remove the top cover tape immediately before LED pick-up.

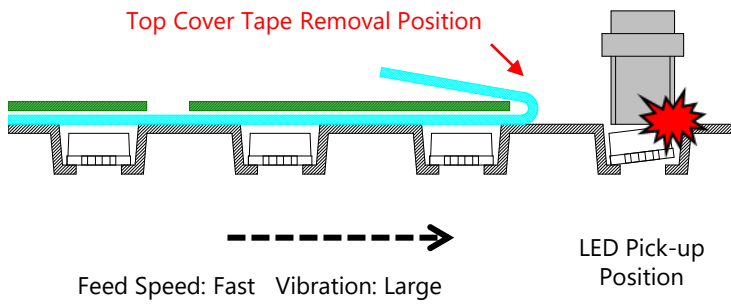

1. For the tape-and-reel feeder, the tape width is set to 8mm and the feeder pitch is set to 4mm.
2. Use a tape-and-reel feeder that ensures it does not create excessive vibrations causing assembly issues (e.g. an electrical [motorized] feeder).
 - When the tape feeder feed rate is fast, the LEDs in the embossed carrier tape pockets may not be in the correct position when picked by the nozzle; it may be improved by reducing the tape feeder feed rate.
3. It is recommended to remove the top cover tape at a point sufficiently far away from the LED pick-up position.

• If the top cover tape is removed right next to where the nozzle picks up the LEDs, regardless of whether the LEDs have been baked or not, it may cause the LED to be picked up incorrectly; it is recommended to remove the top cover tape further from where the nozzle picks up the LEDs.

Figure 5. Examples of Recommended/Not Recommended Top Cover Tape Removal Positions

4-3. Recommended Nozzle Height for Pick-up Operations

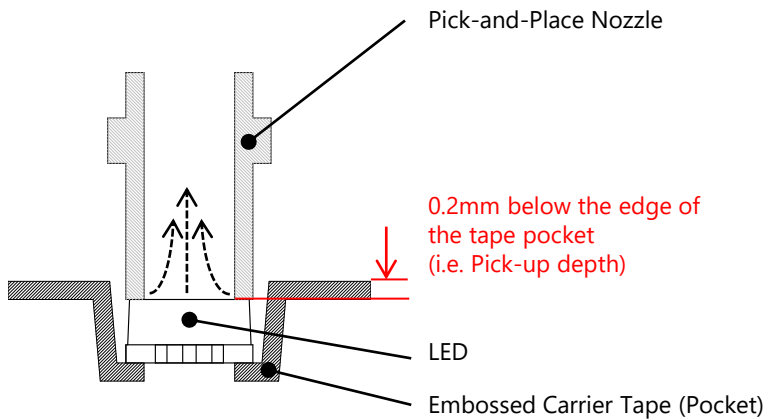

Figure 6. Recommended Nozzle Height for Pick-up Operations

4-4. Recommended Nozzle Height for Placement Operations (Placement Depth)

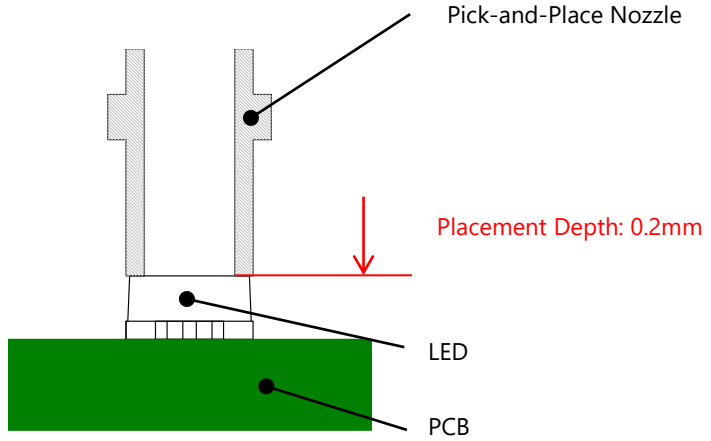

Figure 7. Recommended Nozzle Height for Placement Operations (Placement Depth)

1. Ensure that the nozzle goes down onto the LED in the tape pocket until the tip touches the flat surface of the LED.
Pick-up depth: 0.2mm around the lens
Note: If the reference level for the nozzle setting is at the edge of the tape pocket.
2. The recommended nozzle height for pick-up operations has been determined by Nichia under the verification conditions and may not function as expected with some other pick-and-place machines. If the pick-up operations are unstable even with using the recommended nozzle height, adjust the nozzle height appropriate for the pick-and-place machine being used.
 - If the pick point of the nozzle is too high,
 - it may cause insufficient suction power leading to picking errors (e.g. the nozzle's failure to pick/lift the LED into the air, incorrect picking causing the LED to tilt when in the air).
 - If the pick point of the nozzle is too low,
 - it may cause issues (e.g. causing the embossed carrier tape to shake, causing the tape pocket to deform) leading to picking failure.
1. The nozzle should further press the LED 0.2mm onto the PCB from the height where the LED first touches solder paste.
 - If the release point of the nozzle is too high,
 - it may cause placement issues (e.g. the LED to stick to the nozzle after placement, the LED to be mounted in an incorrect place/rotated position, the LED to become soldered to the PCB in a tilted position, etc.).
 - If the release point of the nozzle is too low,
 - excessive forces may be applied to the LED during placement and it may cause the LED to become damaged.

This document contains tentative information, Nichia may change the contents without notice.

4-5. Imaging-based Automatic Inspection

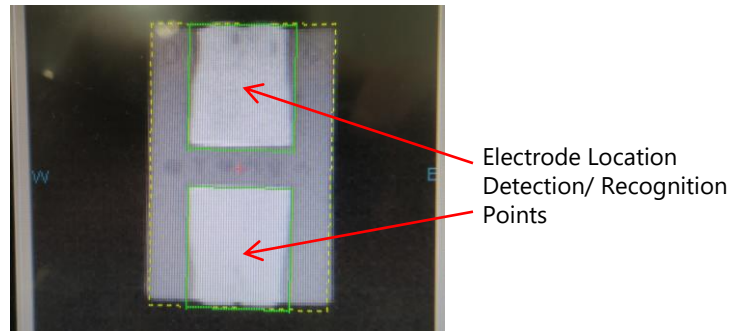

Figure 8. Recommended Reference Points to Detect, Recognize, or Locate the Electrodes

1. Nichia recommends using the electrodes as a reference to locate the center of the LED.
2. If the imaging device has trouble detecting/recognizing the electrodes, adjust the settings (i.e. the brightness of the light, etc.) of the pick-and-place machine.

5. Precautions When Reflow Soldering

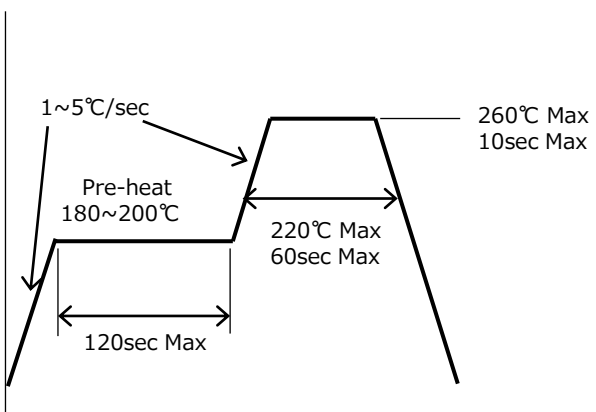

Figure 9. Recommended Reflow Soldering Condition (Lead-free Solder)

1. Reflow soldering must not be performed more than twice.
2. Nichia recommends using the reflow soldering conditions detailed in Figure 9 to the left; use the recommended reflow conditions specified by the manufacturer of the solder paste being used if it works better for the chosen application.

Note: To ensure that these reflow conditions have no negative effect on the LEDs, perform sufficient verification prior to use.

3. When cooling the LEDs from the peak temperature a gradual cooling slope is recommended; do not cool the LEDs rapidly.
4. During reflow soldering, the heat and atmosphere in the reflow oven may cause the optical characteristics to degrade. In particular, reflow soldering performed with an air atmosphere may have a greater negative effect on the optical characteristics than if a nitrogen atmosphere is used; Nichia recommends using a nitrogen reflow atmosphere.

This document contains tentative information, Nichia may change the contents without notice.

6. Evaluation of the Effect of Solder Volume

6-1. Evaluation Method/Conditions

Nichia evaluated the effect of solder volume for reflow-soldering the LEDs using different solder volumes (i.e. four aperture ratios) including the recommended amount provided in Table 3 in Section 3. For details, see Table 6; the aperture ratio for the recommended amount was noted as 100% for the comparison.

1. PCB and LEDs Used for the Evaluation
 - PCB: FR4, copper layer thickness of 35μm, substrate thickness of 1.6mm, metal solder stencil thickness of 100μm
 - LED Part No.: NHSW146A
 - Sample Size: 1600 LEDs per condition
2. Evaluated Items
 - Appearance of the reflow-soldered LEDs and placement accuracy (x and y directions, angular direction, and tilt).

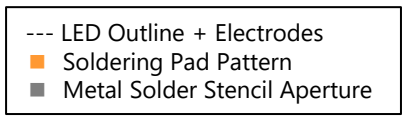

6-2. Evaluation for the Appearance of the Reflow-soldered LEDs

Table 6. Evaluation Result for the Appearance of the Reflow-soldered LEDs for Different Metal Solder Stencil Aperture Conditions (Unit: mm)

Metal Solder Stencil Aperture Ratio	100%	87%	77%	71%
Metal Solder Stencil Aperture				
Appearance of the Reflow-soldered LED				
Evaluation Result	The soldering conditions were good.			

This document contains tentative information, Nichia may change the contents without notice.

6-3. Placement Accuracy in x and y Directions

Nichia evaluated the placement accuracy of the reflow-soldered LEDs in the x and y directions from the center of the soldering pad pattern using different solder volumes (i.e. four aperture ratios). The amount of the deviation from the center of the soldering pad pattern in the x and y directions are described as Δx and Δy respectively.

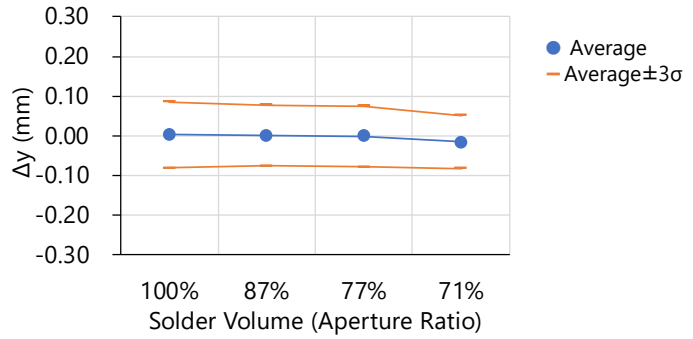
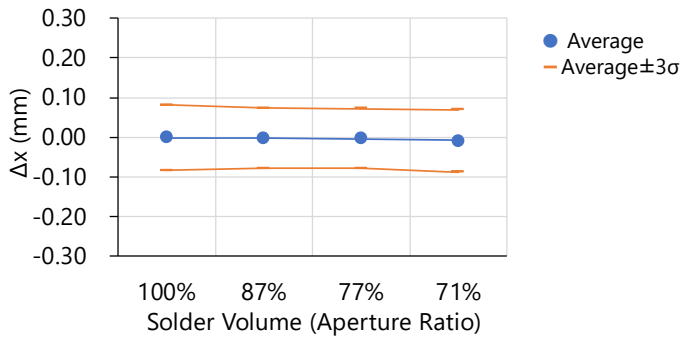
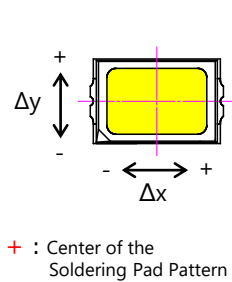

- There was no significant difference seen in the average and the deviation of Δx of the evaluated LEDs per condition.
- There was no significant difference seen in the average and the deviation of Δy of the evaluated LEDs per condition.

6-4. Placement Accuracy in the Angular Direction

Nichia evaluated the placement accuracy of the reflow-soldered LEDs in the angular direction from the reference axis of the soldering pad pattern using different solder (i.e. four aperture ratios). The amount of the deviation from the reference axis in the angular direction is described as $\Delta\theta$.

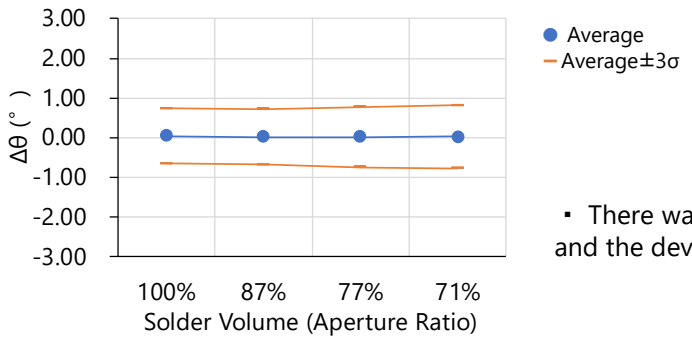
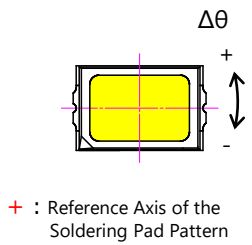

- There was no significant difference seen in the average and the deviation of $\Delta\theta$ of the evaluated LEDs per condition.

This document contains tentative information, Nichia may change the contents without notice.

6-5. Placement Accuracy in the z Direction (Tilt)

Nichia evaluated the placement accuracy of the reflow-soldered LEDs in the z-x and z-y directions; the amount of the deviation is described as Δz .

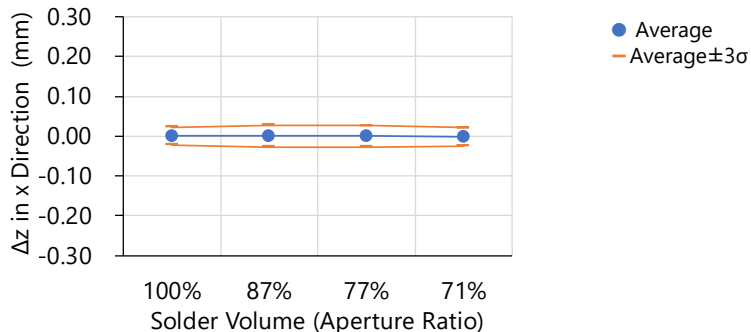
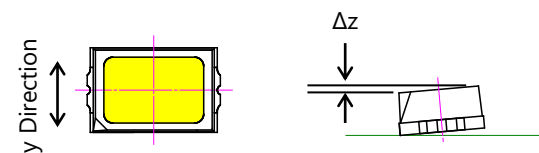
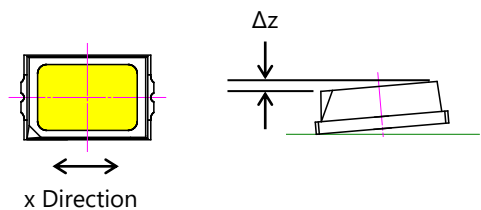

There was no significant difference seen in the average and the deviation of Δz of the evaluated LEDs per condition in the x direction.

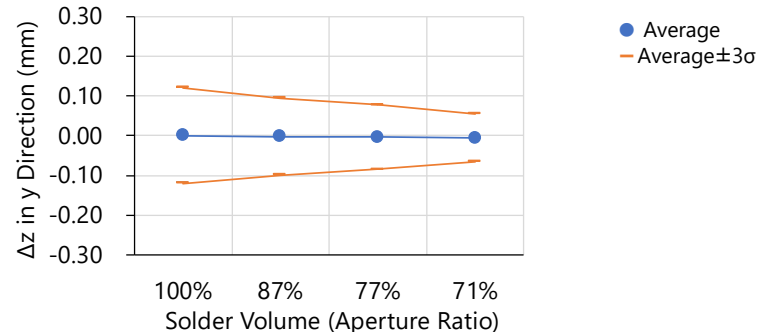

The deviation of Δz of the evaluated LEDs became smaller in the y direction as the solder volume decreased.

The evaluation results provided herein were obtained under Nichia's evaluation conditions/environments; Nichia makes no guarantee that customers will see the same results for their chosen application. Perform a sufficient verification to ensure that there are no issues with the chosen conditions/environments.

Disclaimer

This application note is a controlled document of Nichia Corporation (Nichia) published to provide technical information/data for reference purposes only. By using this application note, the user agrees to the following:

- This application note has been prepared solely for reference on the subject matters incorporated within it and Nichia makes no guarantee that customers will see the same results for their chosen application.
- The information/data contained herein are only typical examples of performances and/or applications for the product. Nichia does not provide any guarantees or grant any license under or immunity from any intellectual property rights or other rights held by Nichia or third parties.
- Nichia makes no representation or warranty, express or implied, as to the accuracy, completeness or usefulness of any information contained herein. In addition, Nichia shall not be liable for any damages or losses arising out of exploiting, using, or downloading or otherwise this document, or any other acts associated with this document.
- The content of this application note may be changed without any prior or subsequent notice.
- Copyrights and all other rights regarding the content of this document are reserved by Nichia or the right holders who have permitted Nichia to use the content. Without prior written consent of Nichia, republication, reproduction, and/or redistribution of the content of this document in any form or by any means, whether in whole or in part, including modifications or derivative works hereof, is strictly prohibited.

NICHIA CORPORATION 491 Oka, Kaminaka-Cho, Anan-Shi,
TOKUSHIMA 774-8601, JAPAN
<http://www.nichia.co.jp> Phone: +81-884-22-2311 Fax: +81-884-21-0148

This document contains tentative information, Nichia may change the contents without notice.